

PARTS LIST			
ITEM	QTY	PART NUMBER	DESCRIPTION
1	1	1057-007-1	M/STEEL GALVANISED RECESSED DISH
2	1	1057-007-2	RUBBER GASKET
3	2	1057-007-3	M/STEEL Z/C PASSIVATED RETAINING PLATE
4	1	1057-007-8	GALVANISED M/STEEL STEEL ASSEMBLY

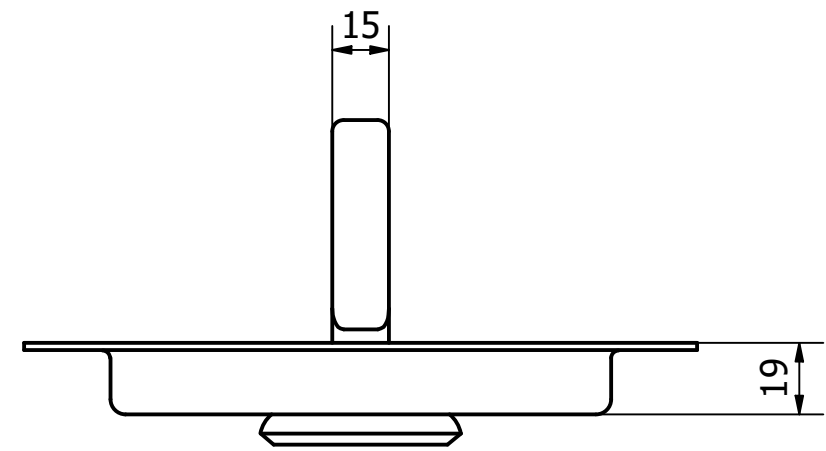
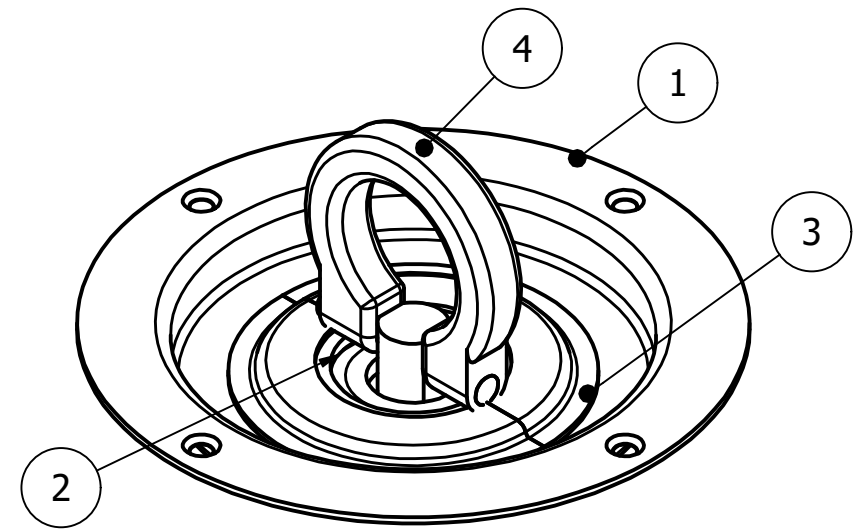

NOTE: S.W.L 2000KG

GENERAL TOLERANCES ON LENGTHS
0.5 - 6 ± 0.1mm
6 - 30 ± 0.2mm
30 - 120 ± 0.3mm
120 - 400 ± 0.5mm
400 - 1000 ± 0.8mm
1000 - 2000 ± 1.2mm
2000 - 4000 ± 2.0mm

ALBERT JAGGER LTD  
 GREEN LANE  
 WALSALL PHONE: 01922 471000  
 WEST MIDLANDS FAX: 01922 648021  
 WS2 8HG

THIS DRAWING & THE DESIGN SHOWN ARE THE PROPERTY OF ALBERT JAGGER LTD AND MUST NOT BE USED OR COPIED BY A THIRD PARTY WITHOUT PERMISSION

DRAWN BY  
K.M

CHECKED BY  
A.P

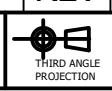

SCALE  
1 : 2

MATERIAL  
M/STEEL

MASS  
0.936 kg

FINISH  
SEE TABLE

Date  
24/02/2020

ALL DIMS IN MM UNLESS STATED DO NOT SCALE

A3



REV	DESCRIPTION	DATE	APPROVED
1	VALIDATION COMPLETE	26/02/2020	A.P

RECESSED PIVOTAL LASHING RING

1057-007

Edition	Sheet
1	1 / 1