

IF IN DOUBT ASK

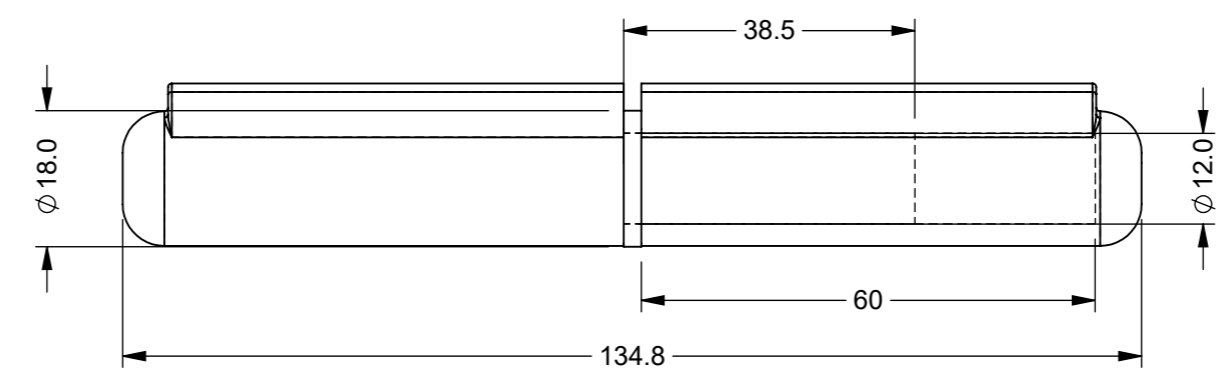

ITEM NO.	PART NUMBER	DESCRIPTION	QTY.
1	2217-008.iam	CARBON STEEL HINGE BASE	1
2	2217-008-2	BRASS BEARING WASHER	1
3	2217-008-3	CARBON STEEL MOUNTING BLOCK	1

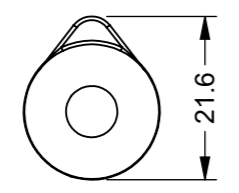
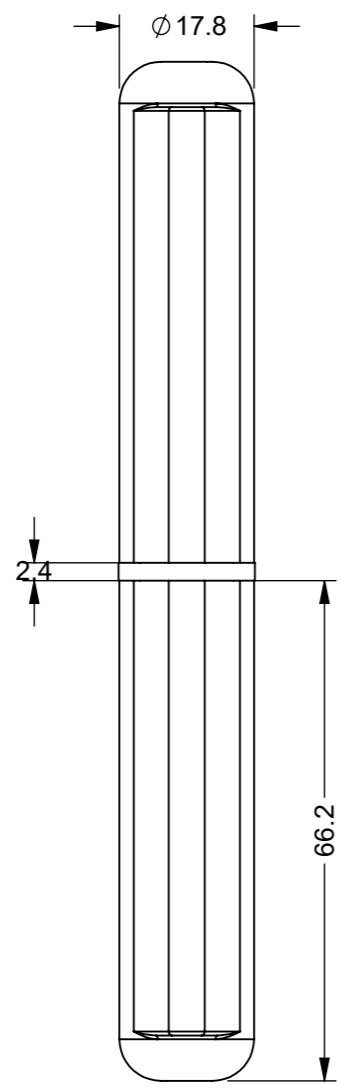
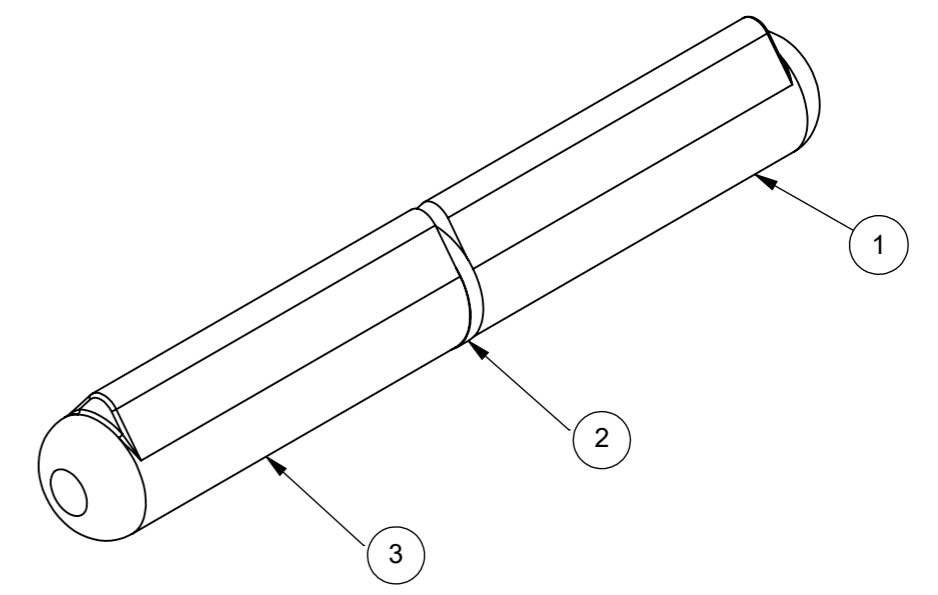

ZONE	REV.	DESCRIPTION	DATE	APPROVED
	2	RE-DRAWN IN SOLIDWORKS & ADDED DIMS	28/07/2023	SR

UNLESS OTHERWISE STATED, ALL DIMENSIONS IN mm

TOLERANCES		SURFACE FINISH 1.6um Ra	
0.5 - 6	= ±0.1mm	FILLET RADII	0.5 TO 1.0
6 - 30	= ±0.2 mm	SQUARENESS	0.05 IN 25
30 - 120	= ±0.3 mm	PARALLELISM	0.05 IN 25
120 - 400	= ±0.5 mm	RUNOUT	0.1
400 - 1000	= ±0.8 mm	ANGLES	±0.5°
1000 - 2000	= ±1.2 mm		
2000 - 4000	= ±2.0 mm		

MATERIAL: SEE TABLE
 MASS: 0.26KG
 FINISH: NATURAL

DRAWN BY: SR
 CHECKED BY: AP
 DESCRIPTION: WELD ON LIFT - OFF HINGE - 134.7 O/A
 APPROVED BY: AP
 ORIGINATION DATE: 28/07/2023
 NUMBER: 2217-008
 REVISION: 2
 SHEET: 1 of 1
 A3

PROPRIETARY RIGHTS ARE INCLUDED IN THE INFORMATION DISCLOSED HEREIN. NEITHER THIS DOCUMENT NOR ANY INFORMATION DISCLOSED SHALL BE REPRODUCED, USED, TRANSFERRED TO OTHER DOCUMENTS, OR DISCLOSED TO OTHERS FOR ANY PURPOSE INCLUDING MANUFACTURING UNLESS SPECIFICALLY AUTHORISED IN WRITING
 REMOVE ALL SHARP EDGES AND BURRS
 PART FINISHING AND MARKING TO CESF001



SCALE : PROPORTIONAL - DO NOT SCALE
 REF SCALE 1:1 WHEN PRINTED ON A3
 PROJECTION 3rd ANGLE