

IF IN DOUBT ASK

ITEM NO.	PART NUMBER	DESCRIPTION	QTY.
1	2217-011.iam	CARBON STEEL HINGE BASE	1
2	2217-011-2	BRASS BEARING WASHER	1
3	2217-011-3	CARBON STEEL MOUNTING BLOCK	1

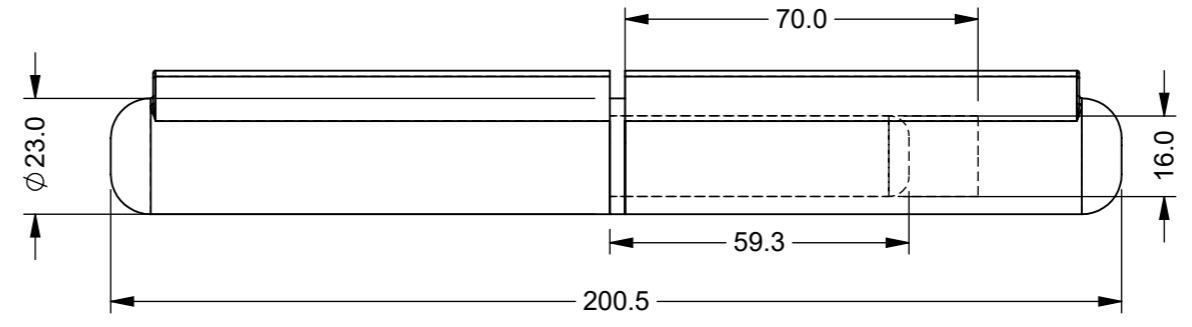
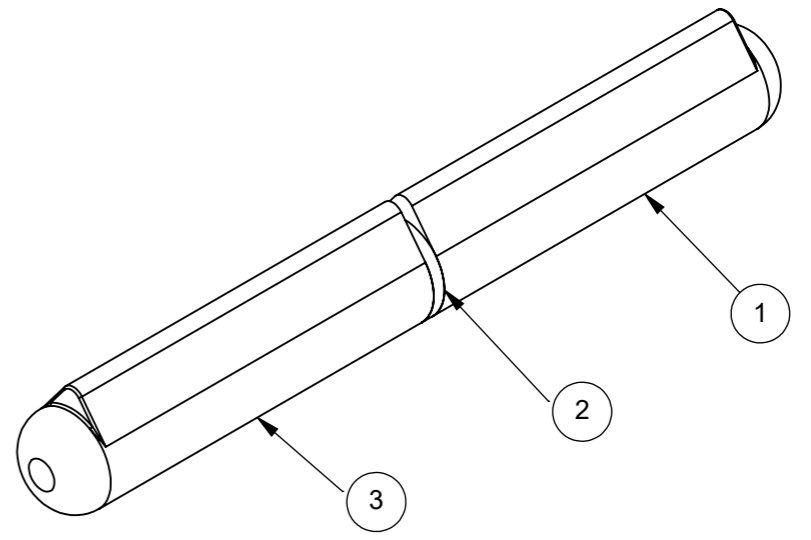
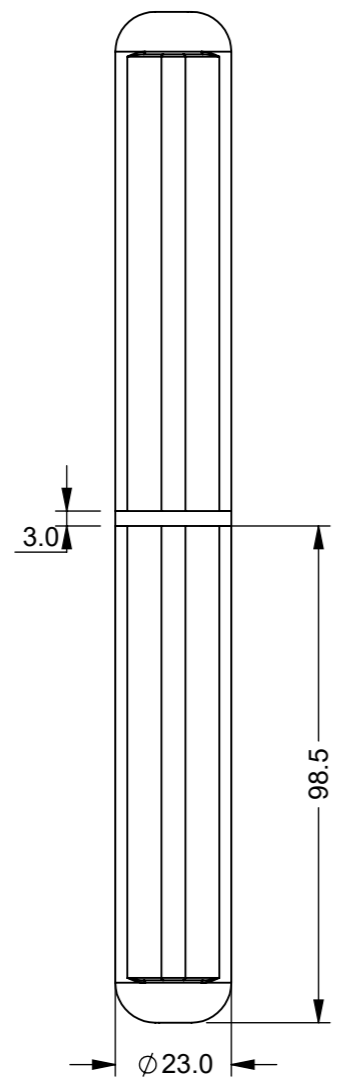

ZONE	REV.	DESCRIPTION	DATE	APPROVED
	2	RE-DRAEN IN SOILDWORKS & ADDED MORE DIMS	27/07/2023	SR

UNLESS OTHERWISE STATED, ALL DIMENSIONS IN mm

TOLERANCES	SURFACE FINISH
0.5 - 6 = ±0.1mm	1.6µm Ra
6 - 30 = ±0.2 mm	FILLET RADII 0.5 TO 1.0
30 - 120 = ±0.3 mm	SQUARENESS 0.05 IN 25
120 - 400 = ±0.5 mm	PARALLELISM 0.05 IN 25
400 - 1000 = ±0.8 mm	RUNOUT 0.1
1000 - 2000 = ±1.2 mm	ANGLES ±0.5°
2000 - 4000 = ±2.0 mm	

MATERIAL: SEE TABLE	DRAWN BY: SR	DESCRIPTION: WELD ON LIFT - OFF HINGE - 200.5 O/A			A3
MASS: 0.68KG	CHECKED BY: AP	NUMBER: 2217-011	REVISION: 2	SHEET: 1 of 1	
FINISH: NATURAL	APPROVED BY: AP	ORIGINATION DATE: 27/07/2023	SCALE : PROPORTIONAL - DO NOT SCALE REF SCALE 1:2 WHEN PRINTED ON A3		

PROPRIETARY RIGHTS ARE INCLUDED IN THE INFORMATION DISCLOSED HEREIN. NEITHER THIS DOCUMENT NOR ANY INFORMATION DISCLOSED SHALL BE REPRODUCED, USED, TRANSFERRED TO OTHER DOCUMENTS, OR DISCLOSED TO OTHERS FOR ANY PURPOSE INCLUDING MANUFACTURING UNLESS SPECIFICALLY AUTHORISED IN WRITING
REMOVE ALL SHARP EDGES AND BURRS
PART FINISHING AND MARKING TO CESF001

